

© All rights in and to this material are the sole property of ASSA ABLOY Entrance Systems AB. of the applicable company within ASSA ABLOY Entrance Systems AB. Rights reserved for changes without prior notice. Copying, scanning, alterations or modifications are expressly forbidden without the prior written consent

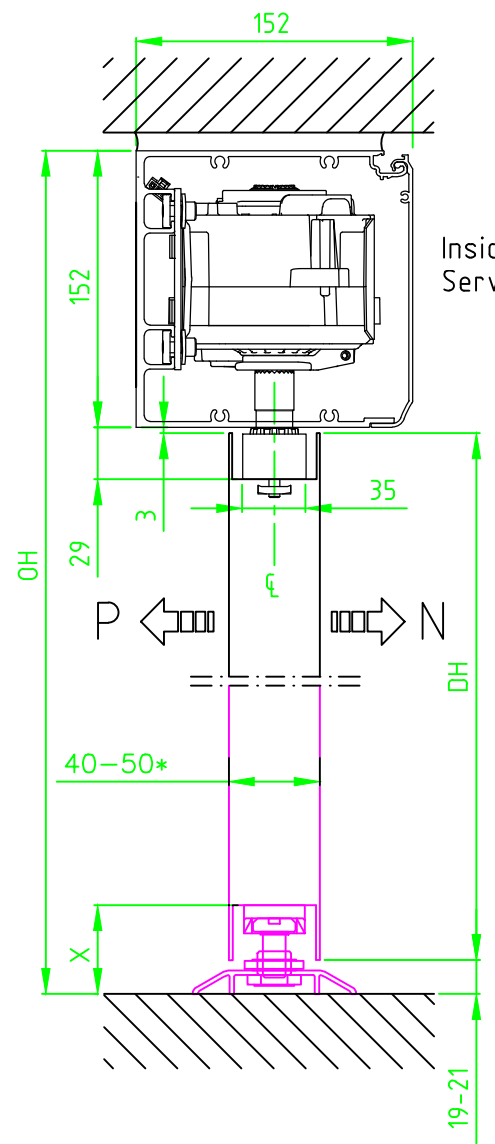

Inside Service side

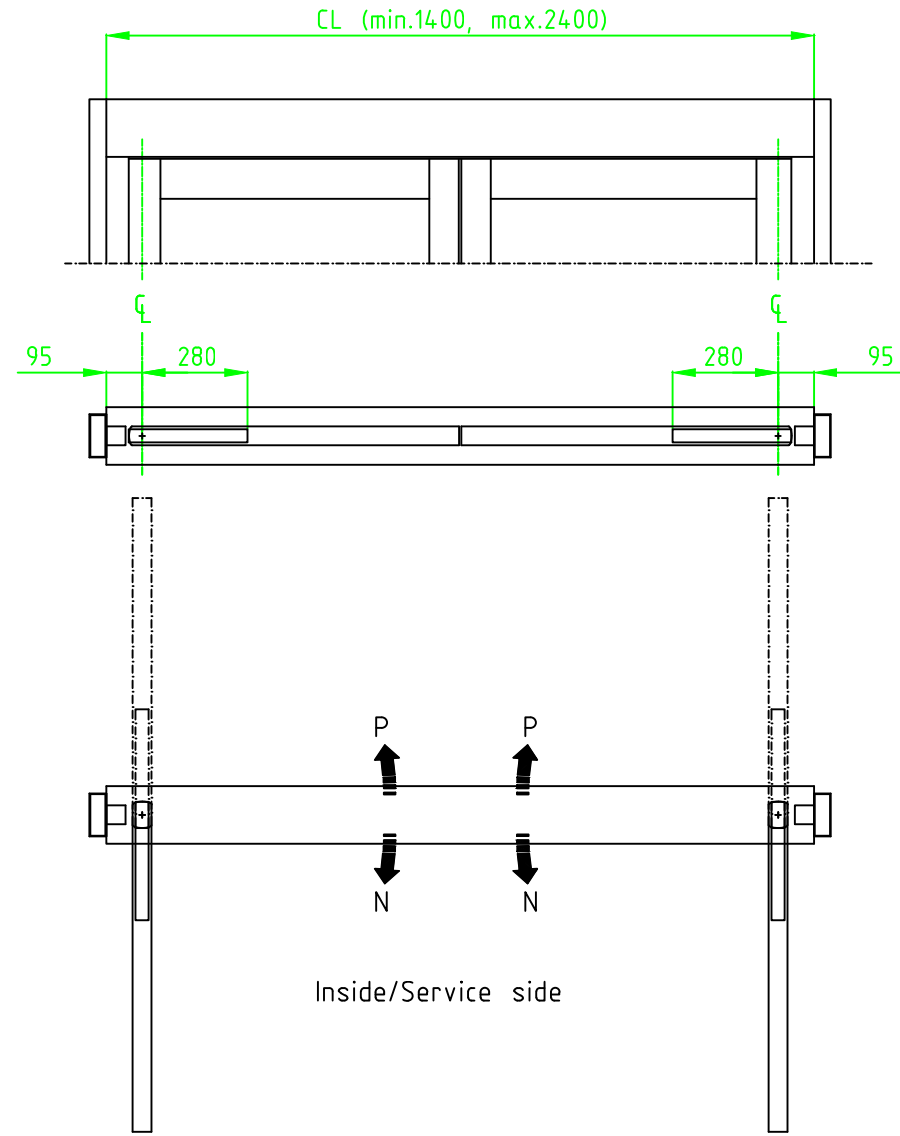

Inside/Service side

STATE WHEN ORDERING

CL = ..... mm

Surface treatment

- Silver anodized
- Special anodized .....
- RAL .....
- Special powder coating .....
- .....

Cover end plates

- BK
- SI

Options see layers:

- Breakaway
- With threshold
- Without threshold

- ☉ = Pivot point
- N = Normal opening direction
- P = Escape opening direction
- CL = Header length
- DH = Door leaf height
- OH = Door opening height
- X = Pivot height
- \* = min. 28 mm if additional Slim arm is used

Customer:	Ref:
Door id:	Date:
Project No:	Sign:

Ref:
Date:
Sign:

Swing door operator  
 Besam SW200i-2:OHC  
 Double, Inswing  
 Art. No. 1010331



3.0
1010331